



# ORIENTERS OR-400 & OR-400S



The increased need for efficient and accurate product orienting at high-speed has resulted in the development of DMW Automation rotary Orienters. These machines are designed to handle a wide variety of products and to be integrated within existing packaging lines.

Depending on the number of orienting stations they are capable of handling products at speeds up to 400ppm, while allowing for quick changeover with minimal operator intervention.

These machines are built around our proven and versatile rotary labeler platform, and are designed to perform a 180-degree, or fully random product orientation.

The product enters the machine via a feed screw and in-feed dial assembly and is placed on a platform on the main dial:

- OR-400: For a 180-degree orientation the in-feed orientation is inspected by a vision camera. Incorrectly oriented product is rotated using DMW patented helix and cam platform rotation. Correctly oriented product is allowed to proceed without rotation.
- OR400S: For an up to 360-degree random orientation each platform is servomotor-driven. Each product is rotated until a sensor detects a specific orienting feature.

In both cases correct orientation can be re-verified prior to the product exiting the machine, and incorrectly oriented product is then automatically rejected.

## SPECIFICATIONS

OR-400 or OR-400S: 5' wide x 6' deep  
Product discharge height: 39" +/-2"  
Power: AC 208, 220, 440, 480 – 3 Phase

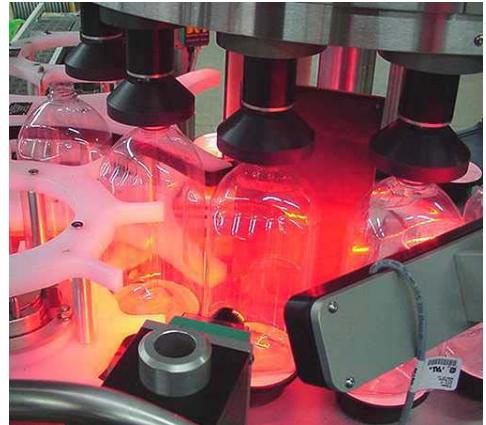
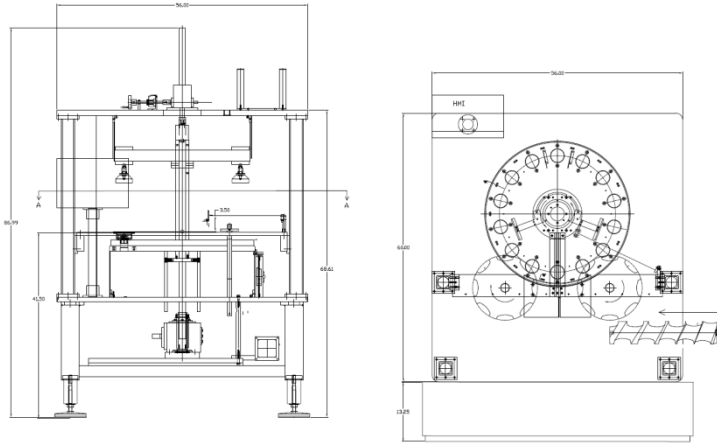

## APPLICATIONS

- Plastic containers
- Glass containers
- Aerosol cans
- Unstable products in puck carriers
- Filled or empty containers

## FEATURES

- Stainless steel clad base
- Fully guarded
- Cammed platforms (OR-400)
- Servomotor-driven platforms (OR-400S)
- Fast tool-less product changeover
- No proprietary electronics



## OPTIONS

- Left or right hand discharge
- Sets of product tooling
- In-feed & out-feed conveyance
- Integration of puck carriers (to run unstable product)
- Vision inspection platforms
- Latest PLC control & operator HMI platforms
- CE and UL certification



2445 E. Oakton Street, Arlington Heights, IL. 60005-4879

Ph: 847-437-0665 Fax: 847-437-0695

[www.DMWAutomation.com](http://www.DMWAutomation.com)



# ORIENTERS OR-400 & OR-400S



The increased need for efficient and accurate product orienting at high-speed has resulted in the development of DMW Automation rotary Orienters. These machines are designed to handle a wide variety of products and to be integrated within existing packaging lines.

Depending on the number of orienting stations they are capable of handling products at speeds up to 400ppm, while allowing for quick changeover with minimal operator intervention.

These machines are built around our proven and versatile rotary labeler platform, and are designed to perform a 180-degree, or fully random product orientation.

The product enters the machine via a feed screw and in-feed dial assembly and is placed on a platform on the main dial:

- OR-400: For a 180-degree orientation the in-feed orientation is inspected by a vision camera. Incorrectly oriented product is rotated using DMW patented helix and cam platform rotation. Correctly oriented product is allowed to proceed without rotation.
- OR400S: For an up to 360-degree random orientation each platform is servomotor-driven. Each product is rotated until a sensor detects a specific orienting feature.

In both cases correct orientation can be re-verified prior to the product exiting the machine, and incorrectly oriented product is then automatically rejected.

## SPECIFICATIONS

OR-400 or OR-400S: 5' wide x 6' deep  
Product discharge height: 39" +/-2"  
Power: AC 208, 220, 440, 480 – 3 Phase

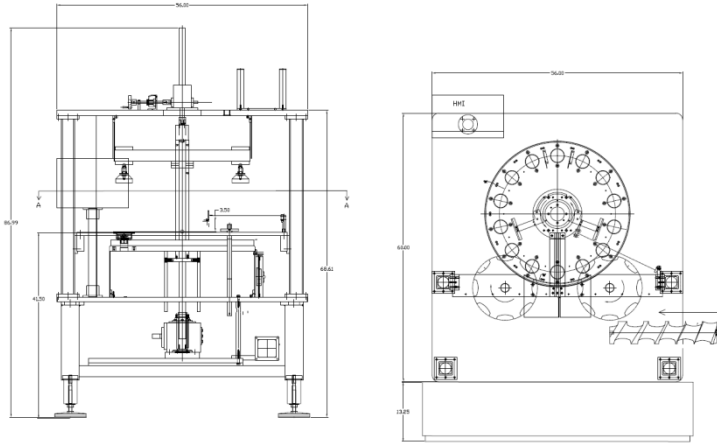

## APPLICATIONS

Plastic containers  
Glass containers  
Aerosol cans  
Unstable products in puck carriers  
Filled or empty containers

## FEATURES

Stainless steel clad base  
Fully guarded  
Cammed platforms (OR-400)  
Servomotor-driven platforms (OR-400S)  
Fast tool-less product changeover  
No proprietary electronics



## OPTIONS

Left or right hand discharge  
Sets of product tooling  
In-feed & out-feed conveyance  
Integration of puck carriers (to run unstable product)  
Vision inspection platforms  
Latest PLC control & operator HMI platforms  
CE and UL certification



2445 E. Oakton Street, Arlington Heights, IL. 60005-4879

Ph: 847-437-0665 Fax: 847-437-0695

[www.DMWAutomation.com](http://www.DMWAutomation.com)